



xantrex

t 1-800-670-0707 (toll-free in North America)

1-360-925-5097 (direct)

f 1-360-925-5143 (direct)

e CustomerService@xantrex.com

www.xantrex.com

Xantrex PRO Inverter XM 1000 and XM 1800

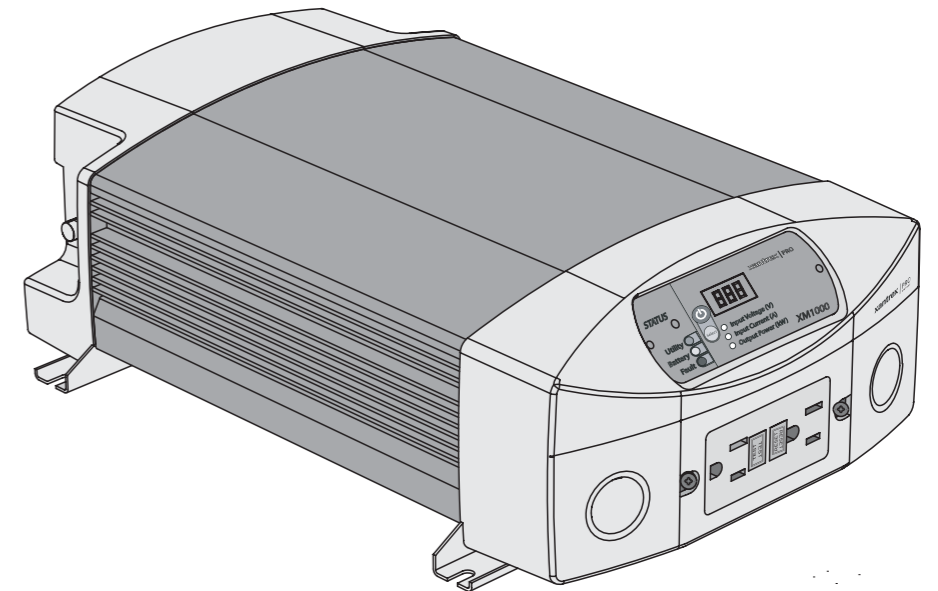

Owner's Guide

Xantrex PRO Inverter

Owner's Guide

About Xantrex

Xantrex Technology Inc. is a world-leading supplier of advanced power electronics and controls with products from 50 watt mobile units to 1 MW utility-scale systems for wind, solar, batteries, fuel cells, microturbines, and backup power applications in both grid-connected and stand-alone systems. Xantrex products include inverters, battery chargers, programmable power supplies, and variable speed drives that convert, supply, control, clean, and distribute electrical power.

Trademarks

Xantrex PRO Inverter is a trademark of Xantrex International. Xantrex is a registered trademark of Xantrex International.

Other trademarks, registered trademarks, and product names are the property of their respective owners and are used herein for identification purposes only.

Notice of Copyright

Xantrex PRO Inverter Owner's Guide © February 2007 Xantrex International. All rights reserved.

Disclaimer

UNLESS SPECIFICALLY AGREED TO IN WRITING, XANTREX TECHNOLOGY INC.
("XANTREX")

(a) MAKES NO WARRANTY AS TO THE ACCURACY, SUFFICIENCY OR SUITABILITY OF ANY TECHNICAL OR OTHER INFORMATION PROVIDED IN ITS MANUALS OR OTHER DOCUMENTATION.

(b) ASSUMES NO RESPONSIBILITY OR LIABILITY FOR LOSS OR DAMAGE, WHETHER DIRECT, INDIRECT, CONSEQUENTIAL OR INCIDENTAL, WHICH MIGHT ARISE OUT OF THE USE OF SUCH INFORMATION. THE USE OF ANY SUCH INFORMATION WILL BE ENTIRELY AT THE USER'S RISK.

Date and Revision

February 2007 Revision C

Manual Part Number

975-0263-01-01

Product Part Numbers

806-1010 (XM 1000)

806-1810 (XM 1800)

Contact Information

Telephone: 1 800 670 0707 (toll-free in North America)
1 360 925 5097 (direct)

Fax: 1 360 925 5143 (direct)

Email: customerservice@xantrex.com

Web: www.xantrex.com

About This Guide

Purpose

The purpose of this Owner's Guide is to provide explanations and procedures for installing, operating, and maintaining the Xantrex PRO Inverter (XM 1800 and XM 1000).

Scope

The Guide provides safety guidelines, detailed planning and setup information, procedures for installing the inverter, as well as information about operating and troubleshooting the installation. It does not provide details about particular brands of batteries. You need to consult individual battery manufacturers for this information.

Audience

The Guide is intended for anyone who needs to install and operate the Xantrex PRO Inverter. Because installation requires compliance with applicable electrical codes, installers should be certified technicians or electricians.

Conventions Used

The following conventions are used in this guide.



WARNING

Warnings identify conditions that could result in personal injury or loss of life



CAUTION

Cautions identify conditions or practices that could result in damage to the unit or other equipment.

Important: These notes describe things which are important for you to know, but not as serious as a caution or warning.

Related Information

You can find more information about Xantrex Technology Inc. and its products and services at **www.xantrex.com**.

Important Safety Instructions



WARNING

This chapter contains important safety and operating instructions. Read and keep this Owner's Guide for future reference.

1. Before installing and using the Xantrex PRO Inverter (XM 1800 or XM 1000), read all instructions and cautionary markings on the inverter, the batteries, and all appropriate sections of this guide.
2. Do not expose the Xantrex PRO Inverter to rain, snow, or spray. To reduce risk of fire hazard, do not cover or obstruct the ventilation openings. Do not install the inverter in a zero-clearance compartment. Overheating may result.
3. Use only attachments recommended or sold by the manufacturer. Doing otherwise may result in a risk of fire, electric shock, or injury to persons.
4. To avoid a risk of fire and electric shock, make sure that existing wiring is in good condition and that wire is not undersized. Do not operate the inverter with damaged or substandard wiring.
5. Do not operate the inverter if it has received a sharp blow, been dropped, or otherwise damaged in any way. If the inverter is damaged, see the Warranty section.
6. Do not disassemble the inverter. It contains no user-serviceable parts. See Warranty for instructions on obtaining service. Attempting to service the inverter yourself may result in a risk of electrical shock or fire. Internal capacitors remain charged after all power is disconnected.
7. To reduce the risk of electrical shock, disconnect both AC and DC power from the inverter before attempting any maintenance or cleaning or working on any circuits connected to the inverter. Turning off controls will not reduce this risk.
8. The inverter must be provided with an equipment-grounding conductor connected to the AC input ground.



WARNING: Risk of injury or loss of life

Do not use Xantrex PRO Inverter in connection with life support systems or other medical equipment or devices.

Explosive Gas Precautions



WARNING: Explosion hazard

1. Working in the vicinity of lead-acid batteries is dangerous. Batteries generate explosive gases during normal operation. Therefore, you must read this guide and follow the instructions exactly before installing or using your Xantrex PRO Inverter.
2. This equipment contains components that tend to produce arcs or sparks. To prevent fire or explosion, do not install the inverter in compartments containing batteries or flammable materials, or in locations that require ignition-protected equipment. This includes any space containing gasoline-powered machinery, fuel tanks, as well as joints, fittings, or other connections between components of the fuel system.
3. To reduce the risk of battery explosion, follow these instructions and those published by the battery manufacturer and the manufacturer of the equipment in which the battery is installed.

Precautions When Working With Batteries



WARNING: Explosion or fire hazard

1. Follow all instructions published by the battery manufacturer and the manufacturer of the equipment in which the battery is installed.
2. Make sure the area around the battery is well ventilated.
3. Never smoke or allow a spark or flame near the engine or batteries.
4. Use caution to reduce the risk of dropping a metal tool on the battery. It could spark or short circuit the battery or other electrical parts and could cause an explosion.
5. Remove all metal items, like rings, bracelets, and watches when working with lead-acid batteries. Lead-acid batteries produce a short circuit current high enough to weld metal to skin, causing a severe burn.
6. Have someone within range of your voice or close enough to come to your aid when you work near a lead-acid battery.
7. Have plenty of fresh water and soap nearby in case battery acid contacts skin, clothing, or eyes.
8. Wear complete eye protection and clothing protection. Avoid touching your eyes while working near batteries.
9. If battery acid contacts skin or clothing, wash immediately with soap and water. If acid enters your eye, immediately flood it with running cold water for at least twenty minutes and get medical attention immediately.
10. If you need to remove a battery, always remove the ground terminal from the battery first. Make sure all accessories are off so you don't cause a spark.

Precautions for Using Rechargeable Appliances



CAUTION: Equipment damage

The output of the inverter is non-sinusoidal.

Most rechargeable battery-operated equipment uses a separate charger or transformer that is plugged into an AC receptacle and produces a low voltage charging output.

Some chargers for small rechargeable batteries can be damaged if connected to the Xantrex PRO Inverter. Do not use the following with the inverter:

- Small battery-operated appliances like flashlights, razors, and night lights that can be plugged directly into an AC receptacle to recharge.
- Some chargers for battery packs used in power hand tools. These affected chargers display a warning label stating that dangerous voltages are present at the battery terminals.

If you are unsure about using your rechargeable appliance with the inverter, contact the equipment manufacturer to determine the rechargeable appliance's compatibility with the modified sinewave (non-sinusoidal) AC waveform.

Contents

Important Safety Instructions	v
1 Introduction	
Quality Power	1-1
Comprehensive Protection	1-2
2 Features	
Materials List	2-1
Front Panel	2-2
Side View	2-2
Rear Panel	2-3
3 Installation	
Designing Your Installation	3-1
Installation Codes	3-4
Calculating Battery Requirements	3-4
Choosing an Effective Charging System	3-4
Choosing an Appropriate Location	3-5
Calculating Cable Sizes	3-6
Calculating Size of DC Input Cables	3-6
Sizing the Chassis Ground Cable	3-7
Calculating Fuse/Circuit Breaker Size	3-8
Installing the XM 1800	3-9
Safety Instructions	3-9
Installation Tools and Materials	3-9
Overview of Installation Steps	3-11
Mounting the Inverter	3-11
Connecting the Chassis Ground	3-12
Grounding Locations	3-12
Chassis Ground Stud	3-13
AC Wiring	3-14
Connecting AC Input	3-15
Connecting AC Output to an Existing AC Circuit	3-17

Contents

Connecting the DC Cables - - - - -	3-22
Testing Your Installation - - - - -	3-24
Testing in Invert Mode - - - - -	3-24
Testing in Shore Power Mode - - - - -	3-25
Installing the Remote Panel - - - - -	3-26

4 Operation

Front Panel Operation - - - - -	4-2
Operating in Shore Power Mode - - - - -	4-3
Operating in Inverter Mode - - - - -	4-3
Turning the Inverter On and Off - - - - -	4-3
Checking Battery Status - - - - -	4-4
Checking Output Power - - - - -	4-4
Operating Several Loads at Once - - - - -	4-4
Turning the Inverter Off When Not Used - - - - -	4-4
Operating Limits - - - - -	4-5
Power Output - - - - -	4-5
Input Voltage - - - - -	4-5
Inverter Loads - - - - -	4-6
Overload Conditions - - - - -	4-6
High Surge Loads - - - - -	4-6
Trouble Loads - - - - -	4-6
Over-temperature Conditions - - - - -	4-7
Routine Maintenance - - - - -	4-7
XM 1800 Unit - - - - -	4-7
Batteries - - - - -	4-7

5 Troubleshooting

Common Problems - - - - -	5-2
Buzz in Audio Equipment - - - - -	5-2
Television Reception - - - - -	5-2
Understanding Fault Codes - - - - -	5-2
Troubleshooting Reference - - - - -	5-4

A Specifications

Electrical Performance	A-1
Physical Specifications	A-2
Mounting Dimensions	A-3

B Battery Types

Battery Types	B-1
Automotive Starting Batteries	B-1
Deep-Cycle Batteries	B-2
Battery Size	B-2
Estimating Battery Requirements	B-4
Battery Sizing Example	B-4
Battery Sizing Worksheet	B-5
Using Multiple Batteries	B-6
Two Batteries Connected In Parallel	B-6
Two Separate Battery Banks	B-6
Battery Tips	B-7

C Alternators and Charging Systems

Charging System Requirements	C-1
Charging With an Engine Alternator	C-2
Using a Standard Vehicle Alternator	C-2
Using a Multi-stage Alternator Regulator	C-2
Using a High-Output Alternator	C-2
Charging From AC Power	C-3
Charging From Alternative Energy Sources	C-3

Warranty and Return Information

WA-1

1

Introduction

Congratulations on your purchase of the Xantrex PRO Inverter (XM 1800 or XM 1000). The XM 1800 has been designed to give you quality power, ease of use, and reliability.

Please take a few moments to read this chapter to familiarize yourself with the main performance features and protection features of the XM 1800.

Quality Power

The XM 1800 is a quality inverter designed for recreational vehicle (RV) electrical systems that have a battery charger or generator already installed.

- The XM 1800 provides up to 1800 watts (XM 1800) or up to 1000 watts (XM 1000) of continuous modified sine wave power from a battery bank. It is designed to handle loads such as 1000 watt (XM 1800) or 600 watt (XM 1000) microwaves, TVs, VCRs, and midsized power tools.
- The XM 1800's high surge capability lets you handle many hard-to-start loads, including large TVs and small refrigerators.
- The built-in transfer switch automatically transfers between inverter power and incoming AC power (shore power) to ensure power is always available.
- A built-in 15 A supplementary circuit breaker protects the XM 1800 from overload conditions to the GFCI receptacles.
- The XM 1800's low standby battery demand means you don't have to worry about excessive drain on your battery if you leave the inverter on for a few days. When the XM 1800 is on but no power is being supplied to a load, the inverter draws, on average, less than 0.5 A (XM 1000) or less than 0.7 A (XM 1800) from the battery.
- The cooling fan in the XM 1800 is both load activated and thermally activated. The fan turns off automatically after the inverter has cooled or the load has decreased.

Comprehensive Protection

The XM 1800 is equipped with numerous protection features to guarantee safe and trouble-free operation:

Low battery alarm Alerts you if the battery has become discharged to 11.0 V or lower.

Low battery voltage shutdown Shuts the XM 1800 down automatically if the battery voltage drops below 10.5 V. This feature protects the battery from being completely discharged.

High battery voltage shutdown Shuts the XM 1800 down automatically if the input voltage rises to 15.5 V or more.

Overload alarm Alerts you if the loads connected to the XM 1800 are close to the inverter's operating limits.

Overload shutdown Shuts the XM 1800 down automatically if the loads connected to the inverter exceed the inverter's operating limits or if a short circuit is detected in the circuitry connected to the inverter's output.

Over-temperature alarm Alerts you if the XM 1800 is running hot and is approaching the over-temperature shutdown level.

Over temperature shutdown Shuts the XM 1800 down automatically if its internal temperature rises above an acceptable level.

These values and thresholds are set at the factory and cannot be adjusted.

2

Features

Chapter 2 describes the main features of the XM 1800.

Xantrex recommends that you familiarize yourself with these features before installing and operating the inverter.

Materials List

Your XM 1800 package includes:

- One XM 1800 inverter
- Two M8 lock washers (on the DC input cable terminals)
- Two M8 nuts (on the DC input cable terminals)
- Two strain reliefs for AC input and output wiring
- Two rubberized input terminal covers
- Owner's Guide.

If any of these materials are missing or are unsatisfactory in any way, please contact Customer Service. Contact information is available on page WA-1.

As soon as you unpack your inverter, be sure to record the product information using the form on page WA-4.

Front Panel

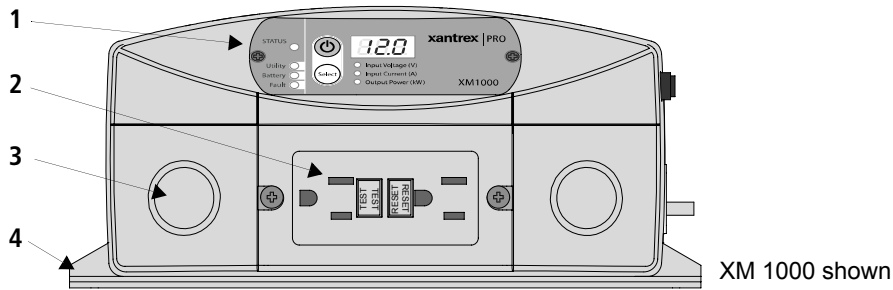

XM 1000 shown

Feature	Description
1	Detachable remote panel to display inverter status and battery status information. For more information about the remote panel, see “Front Panel Operation” on page 4–2.
2	GFCI receptacles provide 1000 W (XM 1000) or 1800 W (XM 1800) of power to operate AC devices. The GFCI receptacles can be removed to access the AC wiring compartment for hardwiring the inverter to an existing AC power system.
3	Knockouts for routing AC input and output wiring in hardwired installations.
4	Mounting flange allows you to mount the inverter permanently.

Side View

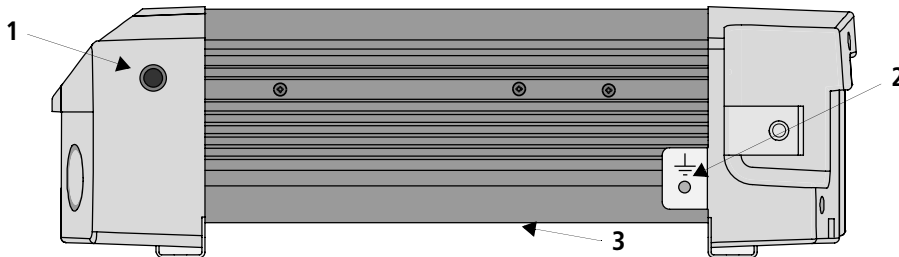

Feature	Description
1	15 A supplementary circuit breaker provides overload protection for the GFCI receptacles. In a hardwired installation, the supplementary circuit breaker does not protect output wiring.
2	Grounding stud connects to vehicle chassis, DC grounding bus or to engine’s negative bus.
3	Cooling fans (XM 1800 only) turn on when powering loads above 500 W, or when the internal temperature rises above 113 °F (45 °C).

Rear Panel

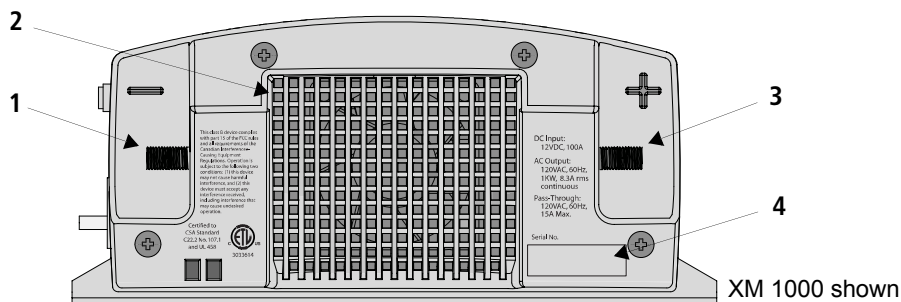

Feature	Description
1	Negative DC cabling terminal connects to the cable connected to the negative terminal of the battery.
2	Ventilation opening must not be obstructed for the proper operation of the cooling fan and inverter. When the inverter is mounted, the ventilation opening must not point up or down.
3	Positive DC cabling terminal connects to the cable connected to the positive terminal of the battery.
4	Serial number of your unit.

3

Installation

Chapter 3 provides information on cables and fuses to help you plan for your installation, and provides procedures for installing the XM 1800.

Xantrex strongly recommends that you read the entire chapter before starting to install the XM 1800, so that you can plan an installation that is suited to your power needs.

Designing Your Installation

Before doing anything else, you need to determine how you are going to use your XM 1800, and then design a power system that will give you maximum performance. The more thorough your planning, the better your power needs will be met. In particular, you will need to:

- Be aware of installation codes
- Calculate your battery requirements
- Choose an effective charging system
- Choose an appropriate location
- Calculate the DC and AC cable sizes
- Select the correct fuses or circuit breakers.

Study Figure 3-1, “DC Input Configuration for Normal Loads” on page 3-2 and Figure 3-2, “DC Input Configuration for Heavy Loads” on page 3-3 for an examples of a setup for normal or heavy loads in a vehicle. When you have decided upon your configuration, then you can calculate battery requirements.

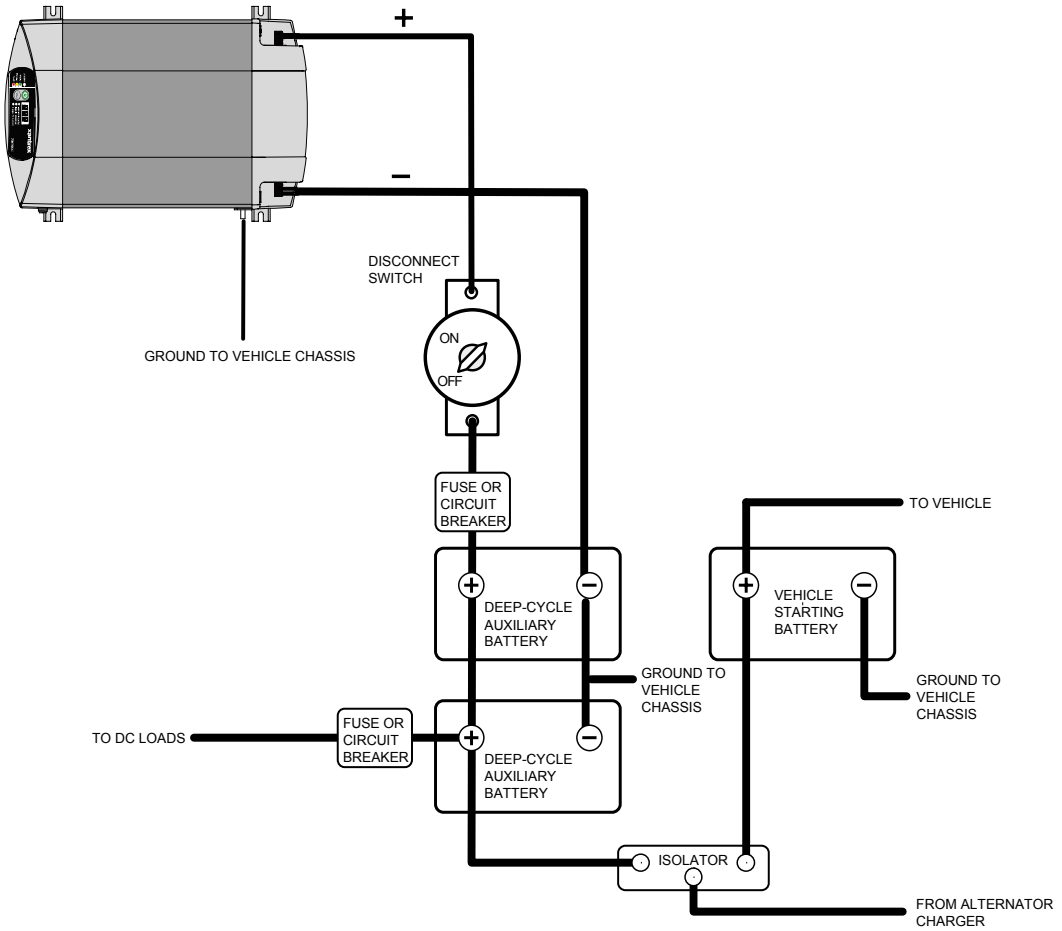

Figure 3-1 DC Input Configuration for Normal Loads

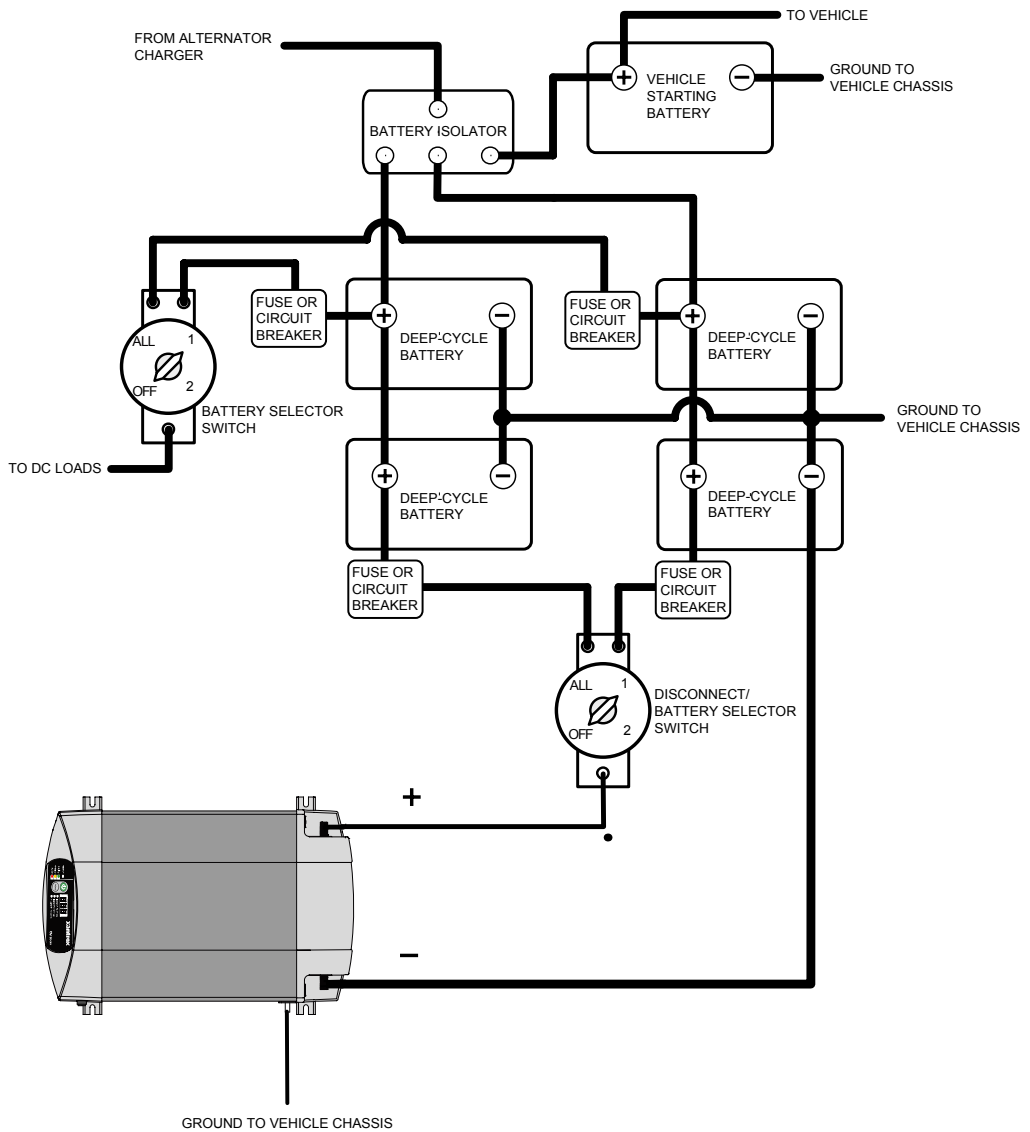

Figure 3-2 DC Input Configuration for Heavy Loads

Installation Codes

Governing installation codes vary depending on the location and type of installation. Electrical installations must meet local and national wiring codes and should be performed by a qualified electrician.

In residential applications, electrical codes do not allow permanent connection of AC distribution wiring to the inverter's AC output receptacles. The receptacles are intended for temporary (as-needed) connection of cord connected loads only.

Calculating Battery Requirements

Battery type and battery size strongly affect the performance of the XM 1800. Therefore, you need to identify the type of loads your inverter will be powering, and how much you will be using them between charges. Once you know how much power you will be using, you can determine how much battery capacity you need. Xantrex recommends that you purchase as much battery capacity as possible.

Consult Appendix B, "Battery Types" for a detailed explanation of how to determine the appropriate number and size of batteries for your needs.



CAUTION

The XM 1800 must only be connected to a 12 volt battery system. It will not operate if connected to a 6 volt battery, and will be damaged if connected to a battery of 16 volts or more.

Choosing an Effective Charging System

The charging system must be appropriate for your particular installation. A well-designed charging system will ensure that power is available when you need it and that your batteries remain in top condition. Inadequate charging will degrade system performance, and the wrong type of charger will reduce battery life.

Consult Appendix C, "Alternators and Charging Systems" for information about choosing an effective charging system.

Choosing an Appropriate Location



WARNING: Explosion or fire hazard

The XM 1800 contains components that may produce arcs or sparks. To prevent fire or explosion, do not install the inverter in compartments containing batteries or flammable materials, or in locations that require Ignition-Protected equipment such as areas containing gasoline engines, tanks, or fuel-line fittings.



WARNING: Fire hazard

To reduce the risk of fire, do not cover or obstruct the ventilation openings. Do not install the XM 1800 in a zero-clearance compartment. Overheating may result.

The XM 1800 must only be installed in a location that is:

Dry	Do not allow water or other liquids to drip or splash on it.
Cool	Ambient air temperature should be between 32 °F and 105 °F (0 °C and 40 °C)—the cooler the better within this range.
Ventilated	Allow at least 3 inches (7.5 cm) of clearance around the inverter for air flow. Ensure that the ventilation openings on the DC end of the unit are not obstructed.
Safe	Do not install the inverter in the same compartment as batteries or in any compartment capable of storing flammable liquids like gasoline.
Close to battery	Do not use excessive DC cable lengths. DC cable wire resistance and the resulting voltage drop reduces input power. Voltage drop in AC wires is of less critical importance because resistance in wire carrying AC current is less. AC wires are also less expensive. In general, longer AC wires are preferable to longer DC cables.
Protected from battery gases	Do not mount the inverter where it will be exposed to gases produced by batteries. Battery gases are corrosive, and prolonged exposure to battery gases will damage the inverter.

Calculating Cable Sizes

To operate safely and effectively, the XM 1800 needs proper cables and fuses. Because the XM 1800 has low-voltage and high-current input, it is essential that you use low-resistance wiring between the battery and the inverter to deliver the maximum amount of usable energy to your load.

For safe and efficient operation, you will need to calculate cable sizes for your:

- DC input cables from the battery to inverter (one way)
- Chassis ground cable from the grounding point to the chassis ground screw on the inverter's DC panel.

See Figure 3-3 on page 3–12.



WARNING: Fire hazard

Never use a DC cable longer than 5 feet (1.5 meters). A cable longer than 5 feet (1.5 meters) can potentially generate enough heat to start a fire or result in poor inverter performance.

Calculating Size of DC Input Cables

Refer to Table 3-1 to plan the DC input cabling for your application:

- Use only cable rated for 90 °C
- Oil-resistant cable is recommended
- Keep all cables as short as possible, and ensure that each cable between the inverter and the battery is no longer than 5 feet (1.5 m)
- Do not use aluminum cable. It has about 1/3 more resistance than copper cable of the same size, and it is difficult to make good, low-resistance connections to aluminum wire.

Table 3-1 Recommended DC Input Wire Sizes & Lengths

	RV ^a (Recreational Vehicle)		
	Cable length: Battery to inverter (one way)	Minimum Cable Size	Maximum Battery Fuse Size
XM 1000	Less than 5 feet (1.5 m)	No. 2 AWG	150 ADC
XM 1800	Less than 5 feet (1.5 m)	No. 2/0 AWG	250 ADC

Note: Never use a cable longer than 5 feet (1.5 m) with the XM 1800. Appropriately sized, 90 °C cable can be bought at a welding supply house or a marine supply store.

a. Based on US National Electrical Code NFPA70, Article 551 and Table B310.3, 90C cables.

Sizing the Chassis Ground Cable

See Table 3-2 for the size of the chassis ground cable that runs from the grounding point to the chassis ground stud on the inverter.

Table 3-2 Recommended Chassis Ground Cable size

Application	Minimum chassis ground cable size (Stranded cable is recommended)
Recreational Vehicle ^a	No. 8 AWG

Note: There are no restrictions on length for the chassis ground cable.

a. Based on US National Electrical Code NFPA70, Article 551, par. 551-20c.

Calculating Fuse/Circuit Breaker Size

Because your batteries can provide thousands of amps of short-circuit current, you need fuses or circuit breakers that can safely interrupt the short-circuit current that the batteries can produce.

To select the correct fuse type and size:

1. Determine the total short-circuit current rating for your batteries. For example:
 - If you are using one battery to power your inverter and its short-circuit current rating is 500 A, the total short-circuit current rating is 500 A.
 - If you are powering your inverter with two 12 V batteries connected in parallel, and each battery has a short-circuit current rating of 500 A, the total short-circuit current rating is 1000 A.
 - If you are powering your inverter with two 6 V batteries connected in series, and each battery has a short-circuit current rating of 500 A, the total short-circuit current rating is 500 A.

Important: For batteries connected in parallel, the total short-circuit current rating is the sum of the short-circuit current ratings of all of the batteries connected in parallel. For batteries connected in series, the total short-circuit current rating is equal to the short-circuit rating of a single battery.

2. Once you have determined the total short-circuit current rating of your batteries, pick the fuse/circuit breaker's interrupt capacity based on the short-circuit current calculated in step 1.
3. Pick the fuse/circuit breaker's current rating based on the product used: 150 ADC (XM 1000) or 250 ADC (XM 1800).

Fuses can be bought at any marine supply store, RV supply store, or electrical products store.

Installing the XM 1800

Do not proceed with the installation of your XM 1800 until you have read the section “Designing Your Installation” on page 3–1. The more thorough your planning, the better your power needs will be met to achieve maximum performance from your XM 1800.

Safety Instructions

Before you start to install the XM 1800:

- Review the “Important Safety Instructions” on page v.
- Do not attempt your own AC wiring unless you have the knowledge, tools, and experience to do a safe job. Because installation requires compliance with various codes, installers should be certified technicians or electricians.
- Read and follow all Warnings and Cautions in this chapter.

Important: If you have any installation questions or issues, please contact Customer Service. Contact information is available in “Warranty” on page WA–1.

Installation Tools and Materials

Tools

- Wire stripper
- Wrench for DC terminals and ground stud
- Screwdrivers—1/8" slot-head and Phillips
- Crimping tool for fastening lugs and terminals on DC cables. (You may find it more convenient to have the crimp connectors installed onto the DC cable by the store that sells you the cable and/or connectors.)

Materials

The following checklist is a general list of required materials.

- Four corrosion-resistant fasteners sized #10 (M4.5) for mounting the inverter
- Copper DC input cable as calculated in Table 3-1 on page 3–7
- Two 3/8 inch (M8) ring terminals sized for the cable diameter to connect the DC cables to the DC cabling terminal
- Lugs and terminals to connect the DC cables that connect to the battery, disconnect/battery selector switch and fuse holder(s)
- DC fuse(s) as calculated in “Calculating Fuse/Circuit Breaker Size” on page 3–8 and fuse holder(s)
- Copper chassis ground cable as specified in Table 3-2 on page 3–7
- Ring terminal (appropriately sized to connect copper cable to chassis ground stud) that meets the following specifications:
 - #8 (M4) stud
 - UL/CSA approved
 - copper
 - tin-plated
- Battery isolator (if connecting to a multiple-battery system)
- Disconnect/battery selector switch
- Optional: 2 × 15 A circuit breakers (XM 1000) or 2 × 20 A circuit breakers (XM 1800), used for hard wiring the AC input and AC output to an existing AC circuit.
- Optional: Multi-stage alternator regulator¹
- Optional: High-output alternator¹

Important: The product comes with the items listed on page 2-1. If you have lost any of these items, an accessory kit of fasteners is available under Xantrex part number 808-7119. Please visit www.xantrex.com/buy.asp to order.

1. Consult Appendix B, “Battery Types” and Appendix C, “Alternators and Charging Systems” to determine whether you need these components.

Overview of Installation Steps

Installing the XM 1800 includes the following steps.

1. Ensure that AC and DC power is off.
2. Mount the inverter
3. Connect the chassis ground
4. Connect AC input (if connecting to an existing AC circuit)
5. Connect AC output (if connecting to an existing AC circuit)
6. Connect the DC cables
7. Close the DC disconnect switch.

Do not proceed with installation until you have read “Designing Your Installation” on page 3–1.

Mounting the Inverter

You can mount the inverter horizontally or vertically. See “Choosing an Appropriate Location” on page 3–5.

To mount the XM 1800:

1. Select an appropriate mounting location and orientation. The XM 1800 must be oriented in one of the following ways:
 - On or under a horizontal surface.
 - Horizontally on a vertical surface.
The ventilation opening on the DC end must not point up or down.
2. Use the supplied mounting template to mark the positions of the mounting screws.

Or

Hold the inverter against the mounting surface, mark the positions of the mounting screws, and then remove the inverter.

3. Pilot drill the four mounting holes.
4. Fasten the inverter to the mounting surface using corrosion-resistant fasteners sized #10 (M4.5).

Connecting the Chassis Ground



WARNING: Shock hazard

Never operate the XM 1800 without properly connecting the chassis ground. An electrical shock hazard could result from improper grounding.

The XM 1800 has a ground stud on the side of the unit as shown in Figure 3-3. Follow the guidelines in “Grounding Locations” to connect the inverter’s chassis to the ground.

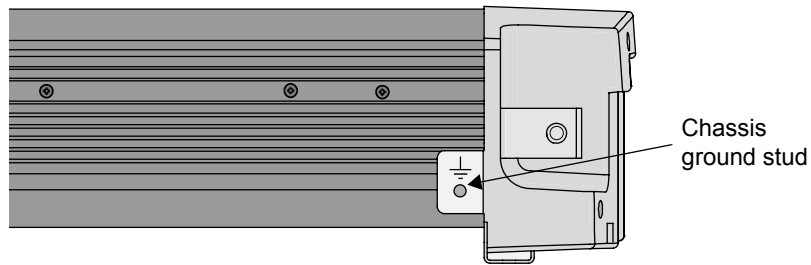

Figure 3-3 DC Panel Connections

Grounding Locations

You must connect the chassis ground stud to a grounding point—usually the vehicle’s chassis—using recommended copper wire (if insulated then green insulation with or without one or more yellow stripes) or larger. For recommended chassis ground cable size, see “Sizing the Chassis Ground Cable” on page 3–7.

Chassis Ground Stud

Xantrex recommends that you attach the grounding cable to the chassis ground stud with a ring terminal. This procedure will ensure that the wire does not slip off the chassis ground stud.

To connect the cable to the chassis ground stud:

1. Remove the ground stud nut and star washer.
2. Strip 1/2 inch (13 mm) to 3/4 inch (19 mm) of insulation from the end of the cable.
3. Attach the ring connector that will join the cable to the chassis ground stud. The connector you use must create a permanent, low-resistance connection. (See “Materials” on page 3–10.)
4. Fit the ring connector and star washer over the stud. The ring connector should be flat against the XM 1800 chassis.
5. Tighten the ground stud nut.

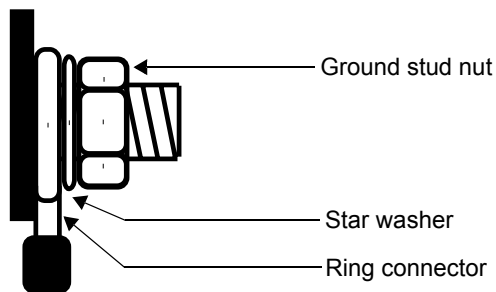

Figure 3-4 Connecting the Grounding Cable

AC Wiring

You can plug loads (12 A continuous, 15 A maximum) directly into the GFCI receptacle on the front panel of the XM 1800. You can also connect the inverter to an existing AC circuit and then plug loads into GFCI receptacles connected to that circuit.

If you plan to use the XM 1800 with the GFCI already installed on the unit, proceed to “Connecting the DC Cables” on page 3–22.

If you plan to hardwire the XM 1800 AC input and output to an existing AC circuit, read this section.

AC wiring includes all the wires and connectors between the AC source and the inverter and all wiring between the inverter and the GFCIs. The type and size of the wiring varies with the installation and load. For some RV applications, flexible multiple-strand wire is required. For residential installations, solid Romex™ cable is often used. Installation codes may specify solid or stranded, overall size of the conductors, and type and temperature rating of the insulation around the wire.

AC wiring must be sized to match the current rating of the AC breakers you provide on the input and output AC circuits in accordance with the electrical codes or regulations applicable to your installation. Table 3-3 is based on the U.S. National Electrical Code and the Canadian Electrical Code, assuming 2-conductor-plus-ground cable. Other codes and regulations may be applicable to your installation.

Table 3-3 Required AC wire size vs. required breaker rating

	Required Breaker Size	Required Wire Size
XM 1000	15 A maximum	14 AWG
XM 1800	20 A maximum	12 AWG

There are two knockouts on the front panel for AC input and output wiring. Use the supplied strain reliefs to prevent wires from being pulled out once wiring is completed.



CAUTION: Equipment damage

The AC wiring terminal block is split into input and output sections. Damage to the inverter will occur if the unit is wired incorrectly.

When making the AC input and AC output connections, observe the correct color code for the appropriate AC wire, as described in Table 3-4.

Table 3-4 Color codes for typical AC wiring

Color	AC Wire
Black	Line
White	Neutral
Green or bare copper	Ground

Connecting AC Input



WARNING: Shock, fire, and energy hazards

Make sure wiring is disconnected from all electrical sources before handling. All wiring must be done in accordance with local and national electrical wiring codes. Do not connect the output leads of the inverter to any incoming AC source.

-
1. Install the required circuit breaker in the AC output panel supplying the unit (See Figure 3-6 on page 3–20).
 2. Ensure AC power is disconnected from the wire you intend to connect to the XM 1800.
 3. Remove the screws securing the GFCI and pull out the GFCI.
 4. Remove the GFCI.
 5. Remove the right-hand side AC wiring knockout from the front of the unit (see Figure 3-5 on page 3–16).
 6. Install a supplied strain-relief clamp in the AC knockout.
 7. Locate the terminal block.

The two input terminals are labelled as follows:

- N (neutral)
- L (line)

A separate screw is provided to connect the AC input ground (see Figure 3-5 on page 3–16).

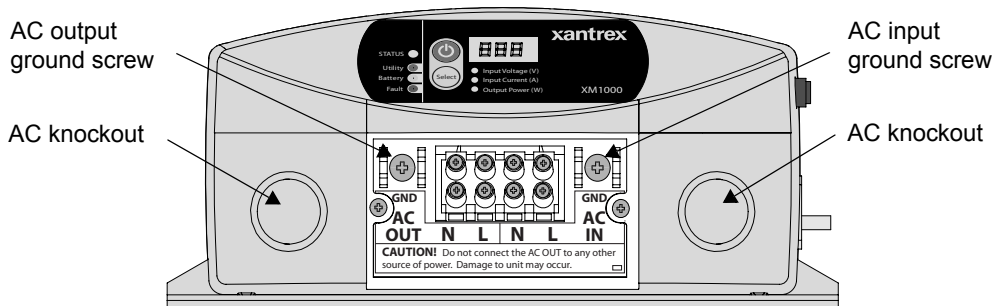

Figure 3-5 XM 1800 AC Wiring Compartment

8. Strip about 2 inches (50 mm) from the jacket of the AC input cable.
The AC input cable may be either solid or stranded, but must have three conductors and be sized as in Table 3-3 on page 3–14. (The AC terminal block accepts wire sizes up to No. 10 AWG.)
9. Strip approximately 3/8 inch (10 mm) off the insulation of each conductor.
10. Run the AC cable through the right-hand side strain-relief clamp and into the wiring compartment.
11. Fasten the Ground wire to the grounding screw.
12. Using the 1/8 inch slot screwdriver, loosen the wire attachment screws on the terminals.



CAUTION: Reverse polarity

Improper connections (connecting a line conductor to a neutral conductor, for example) will cause the XM 1800 to malfunction and may permanently damage the inverter. Damage caused by a reverse polarity connection is not covered by your warranty.

13. Insert the Line and Neutral wires into the corresponding terminals.
14. Tighten the wire attachment screws to a torque of 1.3–1.8 lbf-ft (1.76–2.44 Nm). Leave some wiring slack inside the wiring compartment.

15. Secure the strain-relief clamp.
16. See “Connecting AC Output to an Existing AC Circuit” on page 3–17.
17. Reinstall the GFCI to the unit.

Alternatively, if you do not reinstall the GFCI, make sure that you cap the exposed wires and install a blanking plate to cover the space vacated by the GFCI.

Connecting AC Output to an Existing AC Circuit



WARNING: Shock hazard

Maintain correct wiring polarity.

Do not connect an AC source (such as a generator or utility power) to the AC wiring output of the XM 1800.

The XM 1000 will not operate if its output is connected to AC voltage from another source, and potentially hazardous or damaging conditions may occur. These conditions can occur even if the inverter is off.

Do not connect the XM 1800 to an AC branch circuit that has high-power consumption loads.

The XM 1800 will not operate electric heaters, air conditioners, stoves, and other electrical appliances that consume more than 1000 watts (XM 1000) or 1800 watts (XM 1800).

A Xantrex-tested and approved GFCI must be connected to the XM 1800 AC output. Other types may fail to operate properly when connected to the XM 1800. Although you can reuse the factory-installed GFCI, Xantrex has also tested and approved the following GFCIs for use with the XM 1800:

Make	Model
Hubbell	GFR5252
Leviton	6598 8598

For more information about GFCIs, see the application note “Using GFCI Receptacles on Xantrex Inverters and Inverter/Chargers” in the Document Library at www.xantrex.com.



WARNING: Shock, fire, and energy hazards

Make sure wiring is disconnected from all electrical sources before handling. All wiring must be done in accordance with local and national electrical wiring codes. Do not connect the output leads of the inverter to any incoming AC source.

To make a permanent connection to existing AC wiring:

1. Install the required circuit breaker in the AC load panel (see Figure 3-6 on page 3–20 and Figure 3-7 on page 3–21).
2. Ensure AC power is turned off.
3. Remove the left-hand side AC wiring knockout from the front of the unit.

Important: The applicable installation code may not allow you to run the AC IN and AC OUT wiring through the same AC knockout.

4. Install a supplied strain-relief clamp in the AC knockout.
5. Locate the terminal block.

The two output terminals are labelled as follows:

- N (neutral)
- L (line)

A separate screw is provided to connect the AC output ground.

6. Strip about 2 inches (50 mm) from the jacket of the AC output cable.
The AC output cable may be either solid or stranded, but must have three conductors and sized as in Table 3-3 on page 3–14. (The AC terminal block accepts wire sizes up to No. 10 AWG.)
7. Strip approximately 3/8 inch (10 mm) off the insulation of each conductor.
8. Run the AC cable through the left-hand side strain-relief clamp and into the wiring compartment.
9. Fasten the Ground wire to the grounding screw.
10. Using the 1/8 inch slot screwdriver, loosen the wire attachment screws on the terminals.

**CAUTION: Reverse polarity**

Improper connections (connecting a line conductor to a neutral conductor, for example) will cause the XM 1800 to malfunction and may permanently damage the inverter. Damage caused by a reverse polarity connection is not covered by your warranty.

11. Insert the Line and Neutral wires into the corresponding terminals.
12. Tighten the wire attachment screws to a torque of 1.3–1.8 lbf-ft (1.76–2.44 Nm). Leave some wiring slack inside the wiring compartment.
Ensure you have maintained correct polarity and that there are no loose strands of wire.
13. Secure the strain-relief clamp.
14. Attach the wiring compartment cover.
15. Connect the outgoing AC wires to the AC load panel.

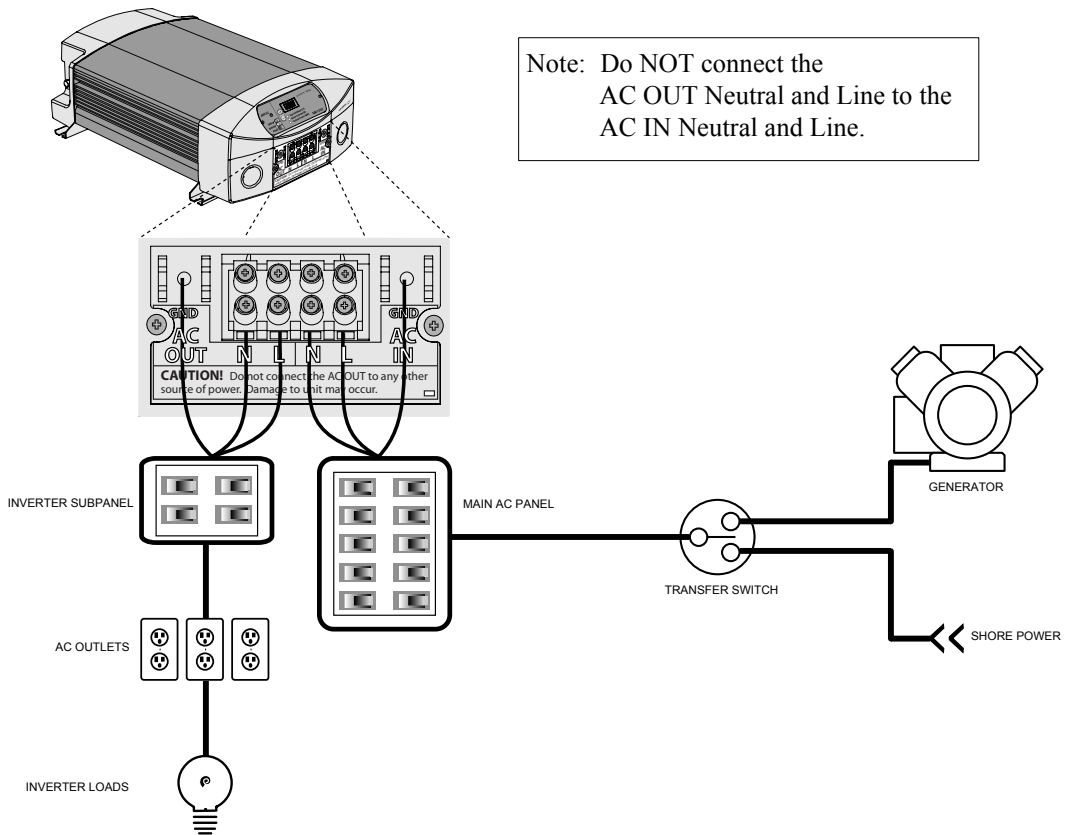

Figure 3-6 AC Wiring Diagram with an Inverter Subpanel

In this wiring diagram, the AC input comes from the main AC panel which acts as the circuit breaker from an AC source. The output is routed to a separate circuit breaker acting as the inverter AC subpanel.

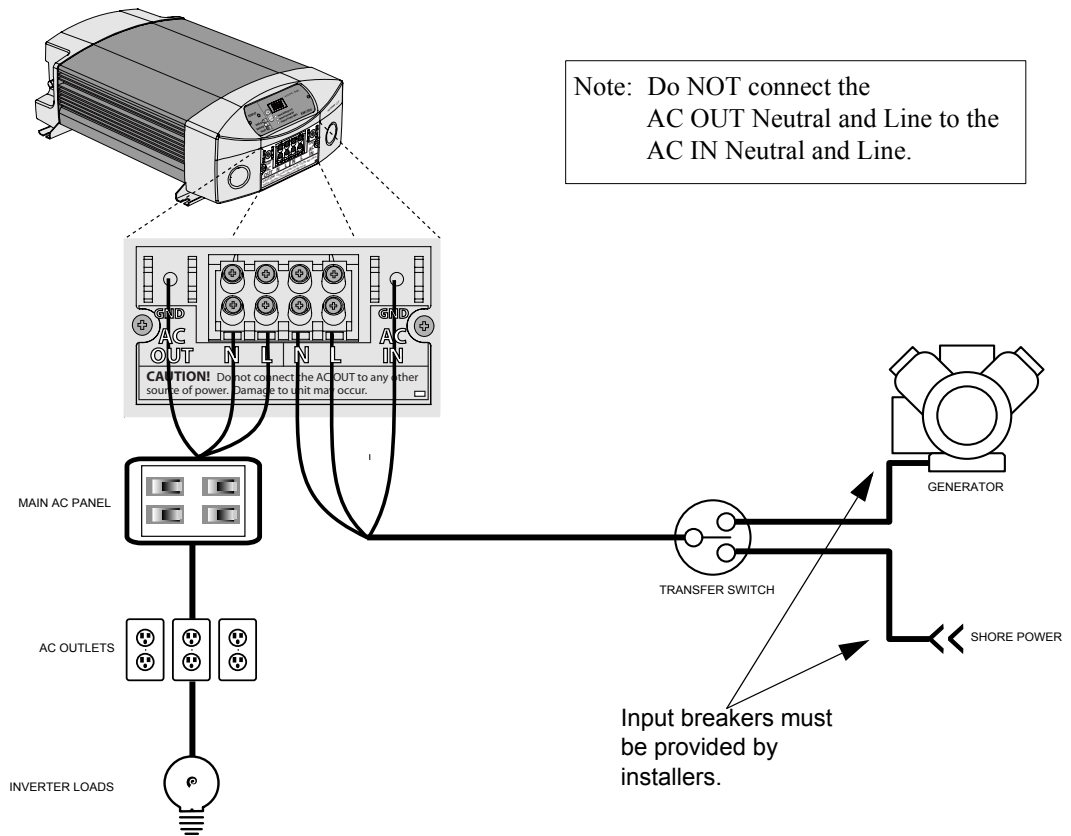

Figure 3-7 AC Wiring Diagram without an Inverter Subpanel

In this wiring diagram, the AC input comes directly from an AC source. The AC input must be limited with (input) breaker protection of 15 amps for the XM1000 and 20 amps for the XM1800. The output is routed to the main AC panel or circuit breaker.

Connecting the DC Cables

Consult Figure 3-1, “DC Input Configuration for Normal Loads” on page 3–2, or, Figure 3-2, “DC Input Configuration for Heavy Loads” on page 3–3, for additional details that are specific to your installation.

To connect the DC cables:

1. Make sure the inverter is off and no AC is connected to the unit.
2. Remove the nuts and washers from the XM 1800 positive and negative DC cabling terminals.
3. Strip 1/2 inch (13 mm) to 3/4 inch (19 mm) insulation from one end of each cable. The amount stripped off will depend on the terminals chosen.
4. Attach the connectors that will join the cables to the battery, disconnect/battery selector switch, and fuse block. The connectors you use must create a permanent, low-resistance connection.
If you are using crimp connectors, use the tool recommended by the terminal manufacturer. Make sure no stray wires protrude from the terminal.
(You may find it more convenient to have the crimp connectors attached by the company that sells you the cable and/or connectors.)
5. For each cable end that will be connected to the inverter, strip 1/2 inch (13 mm) to 3/4 inch (19 mm) of insulation from the cable. The amount stripped off will depend on the terminals chosen.
6. Thread a supplied DC terminal cover over the positive and negative cables. The red cover goes on the positive cable; the black cover on the negative cable.
7. Attach the connector that will join the cable to the DC cabling terminal.
8. Install a fuse and fuse holder in the cable that will be used for the positive side of the DC circuit.
The fuse must:
 - be as close to the battery positive terminal as possible,
 - be rated for DC circuits,
 - have an Ampere Interrupting Capacity (AIC) that exceeds the short-circuit current available from the battery (i.e., Class T fuse).
9. To prevent sparking when making the connection, ensure the disconnect/battery selector switch is off.

10. Attach the connector on the positive cable to the positive DC terminal on the inverter.
11. Install the lock washer and nut that are supplied with the inverter. Tighten the nut to a torque of 108–120 in-lbf (12.2–13.6 N-m). Make the connection snug enough so the ring terminal does not move around on the DC terminal, but do not overtighten. See Figure 3-3, “DC Panel Connections” on page 3–12.

**CAUTION**

Loose connections cause excessive voltage drop and may cause overheated wires and melted insulation.

**CAUTION**

Do not over-tighten the nut on the DC input terminals. Damage to the DC input terminals may result.
The maximum torque setting is **120 in-lbf (13.6 N-m)**.

**CAUTION: Reverse polarity**

DC power connections to the XM 1800 must be positive to positive and negative to negative.
A reverse polarity connection (positive to negative) will blow a fuse in the inverter and may permanently damage the inverter. The fuse is not user replaceable and the inverter may need to be returned for servicing.
Damage caused by a reverse polarity connection is not covered by your warranty.

-
12. Before proceeding, double check that the cable you have just installed connects the positive DC terminal of the inverter to the disconnect/battery selector switch, fuse holder, and that the other end of the fuse holder is connected to the positive terminal on the battery.

**WARNING: Explosion or fire**

Do not complete the next step if flammable fumes are present. Explosion or fire may result if the disconnect/battery selector switch is not in the off position. Thoroughly ventilate the battery compartment before making this connection.

-
13. Connect the cable from the negative post of the battery to the negative DC terminal of the inverter.

14. Install the lock washer and nut that are supplied. Tighten the nut to a torque of 108–120 in-lbf (12.2–13.6 N-m). Make the connection snug enough so the ring terminal does not move around on the DC terminal, but do not overtighten.
15. Slip the DC terminal covers over the XM 1800 DC terminals.
16. Use the disconnect/battery selector switch to select one of the batteries or battery banks (the house bank is preferred over the start bank).

Testing Your Installation



WARNING: Shock hazard

The on/off button on the XM 1800 remote panel does not disconnect DC or AC input power to the XM 1800.

There are two tests to be performed. The first test verifies that the XM 1800 is inverting DC power from the batteries to provide AC power to operate AC devices.

The second test is intended for installations where AC input and output is hardwired to the XM 1800. The test verifies that the XM 1800 transfers from inverter power to shore power when shore power is present.

Note: Shore power (pass-through) refers to the AC input power from a utility grid, generator or external AC source.

When you are ready to test your installation and operate the XM 1800, close the DC fuse and Disconnect or the DC circuit breaker to supply DC power to the XM 1800.

Testing in Invert Mode

To test the XM 1800 in invert mode:

1. For hardwired installations, ensure shore power is not present.
2. Press the on/off button to turn the inverter on.

The status LED on the display panel glows yellow and the LED display illuminates.

3. Plug an appliance within the power rating of the inverter into the XM 1800 GFCI or an AC outlet hardwired to the XM 1800.

4. Turn the appliance on to verify that it operates.

If the appliance operates, your installation is successful. If your installation has AC input and output hardwired to the XM 1800, proceed to “Testing in Shore Power Mode”.

If the status LED on the display panel glows red, see the Troubleshooting chapter.

Testing in Shore Power Mode

To test the XM 1800 in shore power mode:

- ◆ With the appliance from the previous test still connected and operating, connect the shore power source.

The XM 1800 transfers the appliances to shore power. The status LED on the display panel glows green.

If the appliance operates, your installation is successful.

Note: If the on/off button on the XM 1800 is on, the XM 1800 will automatically supply the appliances with inverter power if the shore power source fails or becomes disconnected.

If the on/off button on the XM 1800 is on and shore power voltage is too low (less than 90 volts AC), the unit will transfer to inverter power to continue running your appliances.

Note: Whether or not the on/off button is on, shore power will pass through the XM 1800.

Installing the Remote Panel

You can detach and reinstall the remote panel to monitor and operate the XM 1800 up to 25 feet (7.62 m) away from the unit.

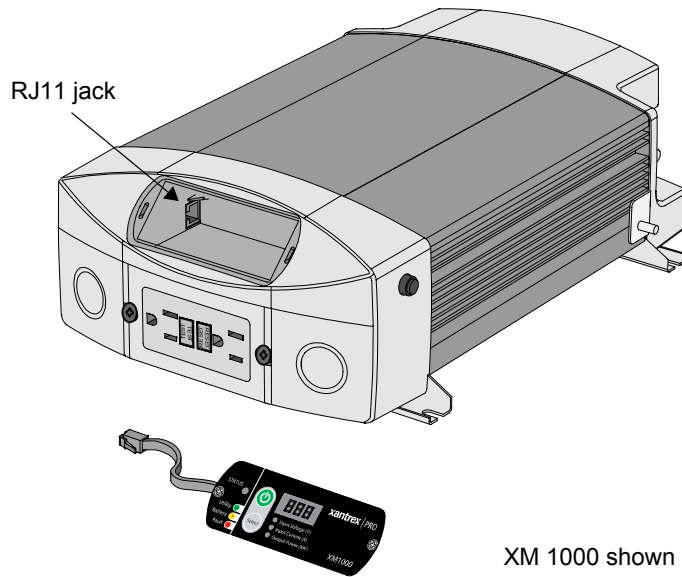

Figure 3-8 XM 1800 with Remote Panel Removed

To install the remote panel in another location, you will need the following tools and materials:

- screwdriver
- jigsaw
- drill (optional)
- RJ11 extension cord, with male and female jacks, with a maximum length of 25 feet (7.62 m).

To install the remote panel in another location:

1. Turn the XM 1800 off.
2. Ensure AC input power is disconnected.
3. Remove the two screws securing the remote panel to the XM 1800 and set them aside.
4. Remove the remote panel and unplug the remote panel RJ11 cord from the jack (see Figure 3-8).

5. Using a jigsaw or other suitable tool, make a hole in the wall or bulkhead into which to insert the remote panel.
The hole should measure 3 1/4 inches (83 mm) across by 1 1/3 inches (33 mm) high, with at least 1 1/2 inches (40 mm) of depth to allow space for the remote panel cord to bend.
6. Plug the male end of the RJ11 extension cord into the XM 1800.
7. Route the RJ11 extension cord (through the wall or behind the bulkhead, if necessary) to emerge from the hole you prepared.
8. Plug the jack from the remote panel cord into the female jack on the extension cord.
9. Secure the remote panel to the wall with the two screws you removed earlier, or with similarly sized screws appropriate for your mounting surface.

4

Operation

Chapter 4 explains how to operate the XM 1800 efficiently and effectively. Specifically, this chapter:

- Gives procedures for operating the inverter from the remote panel
- Discusses operating limits and inverter loads
- Discusses battery charging frequency
- Provides information about routine maintenance.

Front Panel Operation

The XM 1800 features a remote control panel with three-digit LED display to show inverter, AC source, and battery status information.

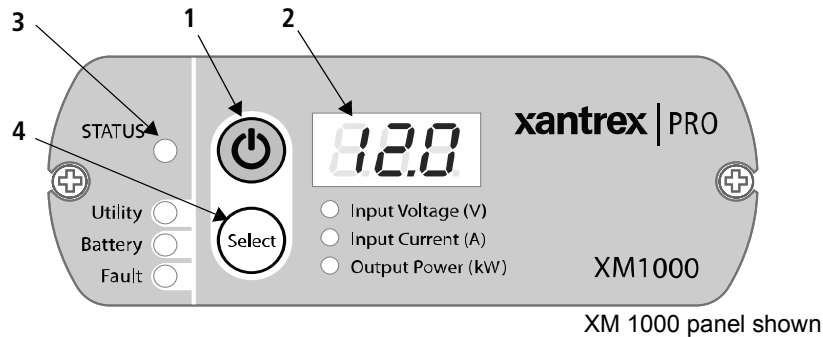

XM 1000 panel shown

Figure 4-1 XM 1800 Remote Panel

Table 4-1 Remote Panel Features

Feature	Description
1	On/Off button. Press once to turn the XM 1800 on or off.
2	Three-digit LED display shows status information and fault codes.
3	Status LED Indicates the mode of operation with a three-color LED. <ul style="list-style-type: none"> • Utility (green) indicates the XM 1800 is in shore power mode, using utility power to operate loads connected to the XM 1800. • Battery (yellow) indicates the XM 1800 is in inverter mode, using the battery to provide AC power. • Fault (red) indicates the XM 1800 has shut down because of a fault. “Understanding Fault Codes” on page 5–2.
4	Select button. When the XM 1800 is in inverter mode, press the Select button to choose what appears in the three-digit LED display: Input Voltage, Input Current, or Output Power.

Operating in Shore Power Mode

The XM 1800 is in shore power mode when an AC source (a generator or utility power) is present to power the appliances connected to the XM 1800. The status LED glows green to indicate that the XM 1800 is using utility (or generator) power. The inverter draws minimal power from the battery.

Whether or not the on/off button is on, shore power will pass through the XM 1800.

When the XM 1800 is on, if the AC source drops to less than 90 Vac or is disconnected, the transfer switch automatically transfers the appliances to inverter power. The status LED glows yellow to indicate the XM 1800 is using the battery to power the appliances.

Operating in Inverter Mode

The XM 1800 is in inverter mode when it is using the battery (inverting DC to AC) to power the appliances connected to the XM 1800.

Turning the Inverter On and Off

The on/off button on the remote panel turns the XM 1800 on and off.

When the XM 1800 is on and shore power is present, the incoming shore power is passed to the output to power appliances connected to the XM 1800, and the inverter draws minimal power from the battery. The status LED glows green. If the shore power goes away, the transfer switch automatically transfers the appliances to inverter power. The status LED glows yellow to indicate the XM 1800 is using the battery to power the appliances.

When the XM 1800 is turned off, the inverter is disabled. Incoming shore power is passed to the output to power appliances. If the shore power goes away, the appliances do not transfer to inverter power.



WARNING: Shock hazard

Turning the XM 1800 off with the on/off button does not disconnect DC battery power from the XM 1800. You must disconnect AC and DC power before working on any circuits connected to the inverter.

Checking Battery Status

You can check the battery status by pressing the Select button until the Input Voltage LED illuminates. The battery voltage appears in the three-digit LED display. The normal operating battery voltage range is between 11 and 15 volts.

Checking Output Power

You can check how much power the XM 1800 is supplying to the connected loads by pressing the Select button until the Output Power LED illuminates.

Operating Several Loads at Once

If you are going to operate several loads from the XM 1800, turn them on one at a time after you have turned the inverter on.

Turning loads on separately helps to ensure that the inverter does not have to deliver the starting current for all the loads at once, and will help prevent an overload shutdown.

Turning the Inverter Off When Not Used

The XM 1800, on average, draws less than 0.5 A (XM 1000) or 0.7 A (XM 1800) from the battery when the inverter is on with no load connected. However, when it is left in this state the XM 1800 will eventually discharge the battery.

To prevent unnecessary battery discharge, turn the XM 1800 off when you are not using it.

Operating Limits

Power Output

The XM 1800 can deliver up to 1000 watts (XM 1000) or 1800 watts (XM 1800) continuous power. The wattage rating applies to resistive loads such as incandescent lights.

Input Voltage

The allowable XM 1800 input voltage ranges are shown in the following table:

Operating Condition	Voltage Range	Comment
Normal	11–15.0 V	
Optimum Performance	12.0–13.0 V	
Low Voltage Alarm	11.0 V or less	The low battery alarm beeps once every two seconds and the display shows fault code E01 alternating with the battery voltage.
Low Voltage Shutdown	Less than 10.5 V	The low battery alarm beeps every second and the display shows fault code E02 alternating with the battery voltage. The status LED turns red and the inverter shuts down to protect the battery from being over-discharged.
High Voltage Shutdown	15.5 V or more	The over-voltage alarm beeps every second and the display shows fault code E03 alternating with the battery voltage. The status LED turns red and the inverter shuts down to protect itself from excessive input voltage. Note: Although the XM 1800 incorporates over-voltage protection, it can still be damaged if input voltage exceeds 16 V.

Inverter Loads

The XM 1800 will operate most AC loads within its power rating of 1000 watts (XM 1000) or 1800 watts (XM 1800). However, some appliances and equipment may be difficult to operate, and other appliances may actually be damaged if you try to operate them with the XM 1800. Please read “High Surge Loads” and “Trouble Loads” carefully.

Overload Conditions

When the XM 1800 senses that the output load is above its output limit (or senses a short circuit at the output), it will shut down. The alarm beeps once a second, and the display shows fault code E05 alternating with “OL”.

High Surge Loads

Some induction motors used in freezers, pumps, and other motor-operated equipment require high surge currents to start. The XM 1800 may not be able to start some of these motors even though their rated current draw is within the inverter’s limits.

Trouble Loads



CAUTION

Some equipment may be damaged by the XM 1800’s modified sine wave output, which is different from pure sine wave utility-supplied electricity.

Some appliances, including the types listed below, may be damaged if they are connected to the XM 1800:

- Speed controllers found in some fans, power tools, kitchen appliances, and other loads may be damaged.
- Some chargers for small rechargeable batteries can be damaged. See “Precautions for Using Rechargeable Appliances” on page viii for details.
- Metal halide arc (HMI) lights can be damaged.

Important: If you are unsure about operating any device with the XM 1800, contact the manufacturer of the device.

Over-temperature Conditions

When the XM 1800 senses its internal temperature approaching its limit, the alarm beeps every two seconds and the display shows fault code E07 alternating with “OtA”.

If the over-temperature condition persists, the XM 1800 shuts down to protect itself. The alarm beeps once per second and the display shows fault code E08 alternating with “Ot”.

Routine Maintenance

XM 1800 Unit

Minimal maintenance is required to keep your XM 1800 operating properly. Periodically you should:

- Clean the exterior of the unit with a damp cloth to prevent the accumulation of dust and dirt.
- Ensure that the DC cables are secure and fasteners are tight.
- Make sure the ventilation openings are not clogged.

Batteries

When possible, you should recharge your batteries whenever a low voltage shutdown occurs with the XM 1800. This gives the batteries a much longer life than recharging when the batteries have been almost completely discharged. For more information on maintaining batteries, see “Battery Tips” on page B-7.

For information about Xantrex battery chargers, see our web site at www.xantrex.com.

5

Troubleshooting

Chapter 5 will help you identify the source of most problems that can occur with the XM 1800.

If you experience a problem with the inverter that is not described in this chapter, please visit www.xantrex.com/support.asp and check the FAQs (Frequently Asked Questions) for your product.

Please review this chapter before contacting Xantrex Customer Service. If you are unable to solve a problem and need to contact Xantrex, record the details on the form “Information About Your System” on page WA-4. This will help our Customer Service Representatives give you better service.

Common Problems

Buzz in Audio Equipment

Some inexpensive stereo systems may emit a buzzing noise from their loudspeakers when operated from the XM 1800. This occurs because the power supply in the audio system does not adequately filter the modified sine wave produced by the inverter. The only solution is to use a sound system that has a higher quality power supply.

Television Reception

When the XM 1800 is operating, it can interfere with television reception on some channels. If interference occurs, try the following:

1. Make sure that the chassis ground stud on the XM 1800 is solidly connected to the ground system of your vehicle or home.
2. Make sure that the television antenna provides an adequate (“snow-free”) signal, and that you are using good quality cable between the antenna and the television.
3. Keep the cables between the battery and the XM 1800 as short as possible, and twist them together with two to three twists per foot. (This minimizes radiated interference from the cables.)
4. Move the television as far away from the XM 1800 as possible.
5. Do not operate high power loads with the XM 1800 while the television is on.

Understanding Fault Codes

This table explains the fault codes that appear on the three-digit display. These codes alert you to the following conditions:

- DC input under-voltage
- DC input over-voltage
- AC overload conditions
- Short circuit
- Over-temperature.

Table 5-1 Fault Codes

Fault Code	Status LED	Description	Solution
E01	Yellow	Under-voltage warning	Check the connections and cable to see if the battery is fully charged. Recharge the battery if it is low. Reduce the load.
E02	Red	Under-voltage shutdown	Disconnect the load and recharge the battery.
E03	Red	Over-voltage shutdown	Make sure the XM 1800 is connected to a 12 V battery.
E04	Yellow	Overload shutdown warning	Make sure the load does not exceed the XM 1800's output rating. Reduce the load if necessary.
E05	Red	Overload shutdown Short circuit	Reduce or disconnect the load. Make sure the load does not exceed the XM 1800's output rating. Check connection to the load.
E06		Not used	
E07	Yellow	Over-temperature shutdown warning	Allow the unit to cool off. Reduce the load if continuous operation is required. Improve ventilation. Make sure the inverter's ventilation openings are not obstructed. Reduce the ambient temperature.
E08	Red	Over-temperature shutdown	Allow the unit to cool off. Improve ventilation. Make sure the inverter's ventilation openings are not obstructed.

Important: In order to reset the unit after an error has occurred, you have to remove shorepower (i.e., AC input), turn the unit off, then turn back on again.

Troubleshooting Reference



WARNING: Electrical shock and burn hazard

Do not disassemble the XM 1800. It does not contain any user-serviceable parts. Attempting to service the unit yourself could result in an electrical shock or burn.

Table 5-2 Troubleshooting Reference

Problem	Possible Cause	Solution
Low output voltage (96 VAC–104 VAC)	You are using a voltmeter that cannot accurately read the RMS voltage of a modified sine wave.	Use a true RMS reading voltmeter such as the Fluke 87.
No output voltage. The Status LED and the display are off.	The inverter is off.	Turn the inverter on.
	No power to the inverter.	Check the wiring to the inverter and to the disconnect/battery selector switch.
	The inverter could have been connected with reverse DC input polarity.	The inverter has probably been damaged. Return the unit. Damage caused by reverse polarity is not covered by the warranty. Information for returning the inverter is provided in “Return Material Authorization Policy” on page WA–3.
	No AC power and DC power.	Connect or apply AC shore power and turn the XM 1800 on.
	15 A supplementary circuit breaker has tripped.	Reset supplementary circuit breaker and turn the XM 1800 on.

Table 5-2 Troubleshooting Reference

Problem	Possible Cause	Solution
<p>No output voltage. The status LED is red.</p>	<p>Low input voltage (fault code E02)</p>	<p>Recharge the battery; check the connections and cable.</p>
	<p>High input voltage (fault code E03)</p>	<p>Make sure the XM 1800 is connected to a 12 V battery.</p> <p>Check the voltage regulation of the charging system.</p>
	<p>Thermal shutdown (fault code E08)</p>	<p>Allow the unit to cool off. Reduce the load if continuous operation is required.</p> <p>Improve ventilation. Make sure the inverter's ventilation openings are not obstructed.</p> <p>Reduce the ambient temperature.</p>
	<p>Unit overload (fault code E05)</p>	<p>Reduce the load. Make sure the load does not exceed the XM 1800's output rating.</p>
	<p>Unit has a short-circuited output (fault code E05).</p>	<p>Remove the short circuit.</p>
<p>No output voltage with shore power connected.</p>	<p>Shore power has dropped below 90 V.</p>	<p>Check shore power voltage. Turn inverter on.</p>
	<p>GFCI has tripped.</p>	<p>Check load, and reset the GFCI.</p>
	<p>15 A supplementary circuit breaker has tripped.</p>	<p>Reset supplementary circuit breaker.</p>
<p>No output voltage in inverter mode.</p>	<p>GFCI has tripped.</p>	<p>Check load, and reset the GFCI.</p>
<p>The problem is not described in this table.</p>		<p>Visit www.xantrex.com/support.asp and check the FAQs (Frequently Asked Questions) for your product.</p>

A

Specifications

Appendix A contains electrical performance and physical specifications for the XM 1000 and XM 1800.

Specifications are subject to change without notice.

Electrical Performance

	XM 1000	XM 1800
Output power at 77 ° F (25 °C) ambient temperature and 12 VDC input: <ul style="list-style-type: none">• Maximum continuous output power• 5 minutes	1000 W 1200 W	1800 W n/a
Surge rating	2000 W	3600 W
Output voltage	115 VAC RMS \pm 10	
Output waveform	Modified sine wave	
Output frequency	60 Hz \pm 1 Hz	
DC input voltage range	10.5–15.5 VDC	
DC low voltage alarm	11.0 V	
DC low voltage cutout	10.5 V	
DC low voltage recovery	12.0 V	
Over-voltage cutout	15.5 V	
AC pass-through low voltage cutout	90 V	
AC pass-through low voltage recovery	100 V	
Optimum efficiency	90%	
No load power draw with inverter on	< 5 W	< 9 W
No load power draw with inverter off	< 1 W	

Physical Specifications

	XM 1000	XM 1800
Length	12 13/16 inches (326 mm)	14 9/16 inches (370 mm)
Width (including mounting flanges)	9 inches (230 mm)	
Height	4 inches (102 mm)	
Weight	7.5 lb (3.4 kg)	10.8 lb (4.9 kg)

Mounting Dimensions

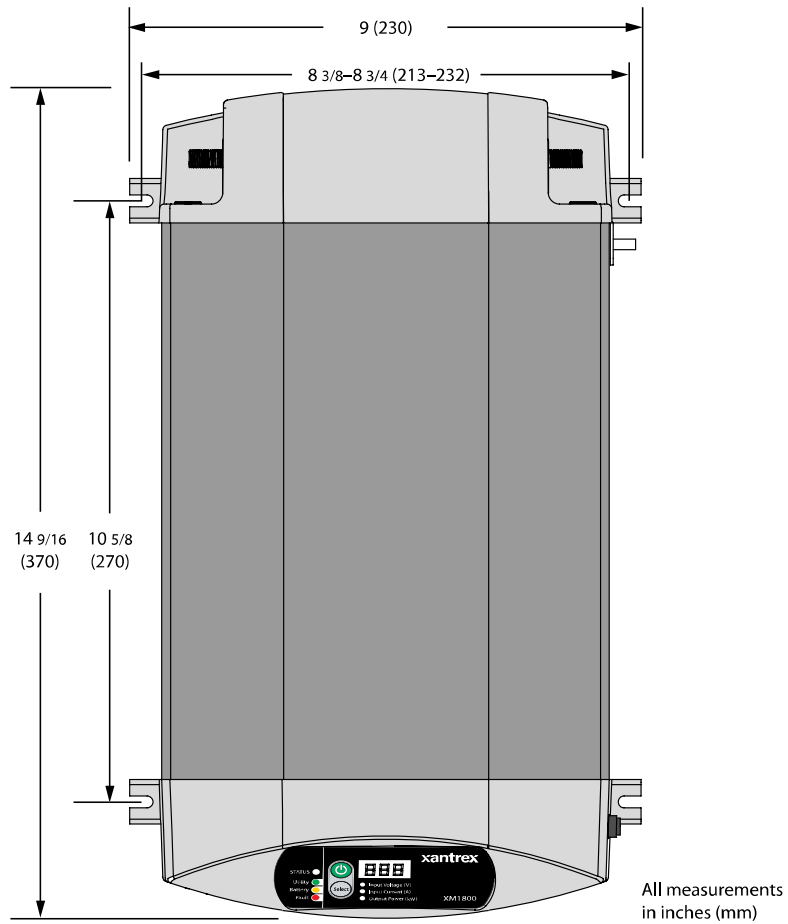

Figure A-1 XM 1800 Mounting Dimensions

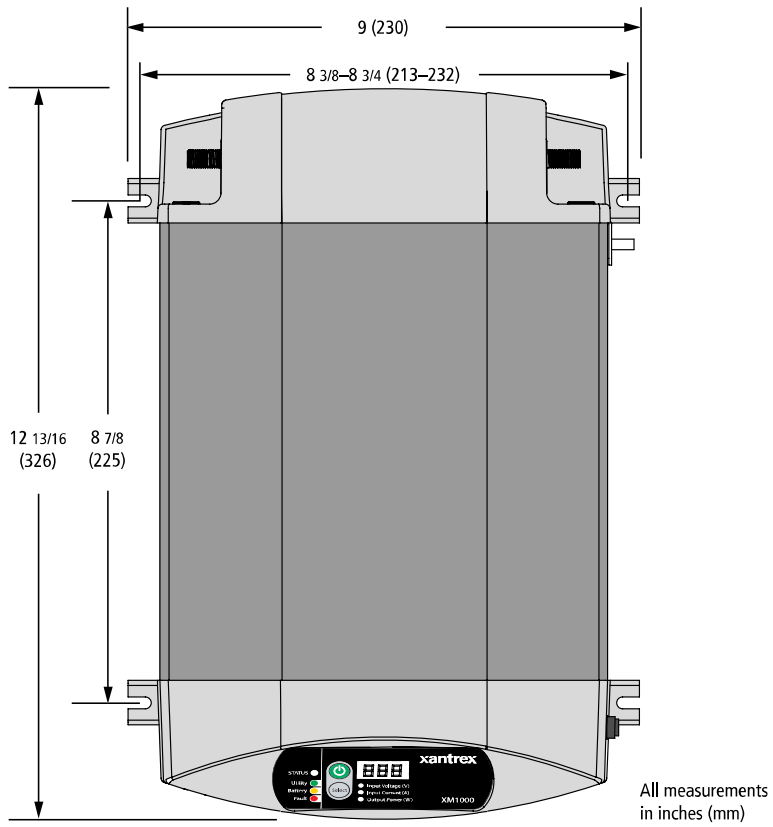

Figure A-2 XM 1000 Mounting Dimensions

B

Battery Types

The information in Chapter B will help you to select, connect, and maintain batteries that are most appropriate for your application.

The batteries that you use strongly affect the performance of the XM 1800. It is important to connect the inverter to the correct size and type of battery.

Battery Types

Automotive Starting Batteries

The lead-acid battery you are most familiar with is probably the starting battery in your vehicle. An automotive starting battery is designed to deliver a large amount of current for a short period of time (so it can start your engine). Only a small portion of the battery's capacity is used when starting the engine, and the spent capacity is quickly recharged by the running engine.

The starting battery in your vehicle is not designed for repeated deep-discharge cycles where the battery is almost completely discharged and then recharged. If a starting battery is used in this kind of deep discharge service, it will wear out very rapidly.

Deep-Cycle Batteries

Deep-cycle batteries are designed for deep discharge service where they will be repeatedly discharged and recharged. They are marketed for use in recreational vehicles, boats, and electric golf carts—so you may see them referred to as RV batteries, marine batteries, or golf cart batteries.

For most applications of the XM 1800, Xantrex recommends that you use one or more deep-cycle batteries that are separated from the vehicle's starting battery by a battery isolator.

A battery isolator is a solid-state electronic circuit that allows equipment to be operated from an auxiliary battery without danger of discharging the vehicle's starting battery. During vehicle operation, the battery isolator automatically directs the charge from the alternator to the battery requiring the charge. Figure 3-1, "DC Input Configuration for Normal Loads" on page 3-2 and Figure 3-2, "DC Input Configuration for Heavy Loads" on page 3-3 show a battery isolator in configurations for normal and heavy-duty loads.

Battery isolators are available at marine and RV dealers and most auto parts stores.

Battery Size



CAUTION

The XM 1800 must only be connected to batteries with a nominal output voltage of 12 volts. The XM 1800 will not operate from a 6 volt battery and will be damaged if connected to a 24 volt battery.

Battery size or capacity is as important as the battery type for efficient operation of your loads. Xantrex recommends that you purchase as much battery capacity as possible.

A number of different standards are used to rate battery energy storage capacity. Automotive starting batteries are normally rated in cranking amps. This is not a relevant rating for continuous loads like an inverter. Deep-cycle batteries use a more suitable rating system, either "amp-hours" ("Ah") or "reserve capacity" in minutes.

Battery Reserve Capacity	Battery reserve capacity is a measure of how long a battery can deliver a certain amount of current—usually 25 amps. For example, a battery with a reserve capacity of 180 minutes can deliver 25 amps for 180 minutes before it is completely discharged.
Amp-hour (Ah) Capacity	<p>Amp-hour capacity is a measure of how many amps a battery can deliver for a specified length of time—usually 20 hours. For example, a typical marine or RV battery rated for 100 Ah can deliver 5 amps for 20 hours ($5 \text{ A} \times 20 \text{ hours} = 100 \text{ Ah}$).</p> <p>This same battery can deliver a higher or lower current for less or more time, limited approximately by the 100 Ah figure (for example, 50 A for 2 hours, or 200 A for 1/2 hour), but usually the capacity figure given is only accurate at the specified rate (20 hours).</p> <p>To calculate the battery capacity you require, read “Estimating Battery Requirements” on page B-4 and “Battery Sizing Example” on page B-4, and then complete the “Battery Sizing Worksheet” on page B-5.</p>

Estimating Battery Requirements

To determine how much battery capacity you need:

1. Determine how many watts are consumed by each appliance that you will operate from the XM 1800. You can normally find the watt rating labelled on the product. If only the current draw is given, multiply it by 115 to get the power consumption in watts.
2. Estimate how many hours each appliance will be operating each day.
3. Calculate the daily watt-hours needed for each appliance.
4. Add the total number of watt-hours needed for all the appliances and multiply it by the number of days between charges.
5. Divide the total watt-hours of AC load between charges by 10. This gives the battery Ah used between charges.
6. Double the total Ah used between charges to get the recommended battery size in Ah.

See the battery sizing example that follows.

Battery Sizing Example

This battery sizing example illustrates a typical calculation, assuming an opportunity to charge the batteries every three days.

Appliance	(A) Power Consumption (Watts)	(B) Operating Time per Day (Hours)	Daily watt-hours needed for this appliance (= A × B)
TV & VCR	200 W	2 hours	400 Wh
Microwave oven	1000 W	20 min. = 1/3 hour	333 Wh
3 lamps, 60 W each	180 W	4 hours	720 Wh
Coffee maker	600 W	15 min. = 1/4 hour	150 Wh
Steam iron	700 W	6 min. = 1/10 hour	70 Wh
Total daily watt-hours of AC load			1673 Wh
× Number of days between charges			3
= Total watt-hours of AC load between charges			5019 Wh
Battery Ah used between charges (divide by 10)			502 Ah
Recommended Battery Bank Size in Ah (multiply by 2)			1004 Ah

This example illustrates how quickly your battery needs can escalate. To reduce the required battery size, you can conserve energy by eliminating or reducing the use of some loads or by re-charging more frequently.

When sizing your battery, resist the temptation to skip the last step of this calculation (multiplying by 2). More capacity is better since you will have more reserve capacity, be better able to handle large loads and surge loads, and your battery won't be discharged as deeply. Battery life is directly dependent on how deeply the battery is discharged. The deeper the discharge, the shorter the battery life.

Battery Sizing Worksheet

Use the following worksheet to calculate your battery needs. To ensure sufficient battery capacity, be generous when estimating the operating time per day for each of the loads you will run.

Appliance	(A) Power Consumption (Watts)	(B) Operating Time per Day (Hours)	Daily watt-hours needed for this appliance (= A × B)
	W	hours	Wh
	W	hours	Wh
	W	hours	Wh
	W	hours	Wh
	W	hours	Wh
	W	hours	Wh
	W	hours	Wh
	W	hours	Wh
Total daily watt-hours of AC load			Wh
× Number of days between charges			
= Total watt-hours of AC load between charges			Wh
Battery Ah used between charges (divide by 10)			Ah
Recommended Battery Bank Size in Ah (multiply by 2)			Ah

Using Multiple Batteries

As your power requirements increase, you may need to use more than one battery to obtain sufficient capacity. Read “Two Batteries Connected In Parallel” and “Two Separate Battery Banks” to determine whether two batteries or two battery banks are more appropriate for your applications.

Two Batteries Connected In Parallel

Two identical batteries can be connected positive (+) to positive (+) and negative (–) to negative (–) in a parallel system. A parallel system doubles capacity and maintains the voltage of a single battery.

Figure 3-1, “DC Input Configuration for Normal Loads” on page 3–2 shows a battery configuration suitable for normal loads.

Figure 3-2, “DC Input Configuration for Heavy Loads” on page 3–3 show a battery configuration that is recommended for heavy loads.



CAUTION

Do not connect the following in parallel:

- batteries made by different manufacturers
- different types of batteries
- batteries that have different Ah ratings.

Decreased battery life and improper charging will result.

Two Separate Battery Banks

If you need more than two batteries (or are using different makes or models of batteries), Xantrex recommends that you install two separate battery banks and a battery selector switch.

Figure 3-2, “DC Input Configuration for Heavy Loads” on page 3–3 shows two separate battery banks and a battery selector switch. This configuration is recommended for heavy-duty applications.

By installing a battery selector switch, you can select between the two battery banks, use both banks in parallel, or disconnect both banks from the load. Battery selector switches are available at marine and RV dealers.

Battery Tips



WARNING

Review “Precautions When Working With Batteries” on page vii before you work with the batteries in your system.

Explosive/
Corrosive
Gases

Lead-acid batteries may emit hydrogen gases, oxygen, and sulfuric acid fumes when recharging. To reduce the risk of explosion:

- Vent the battery compartment to prevent the accumulation of gases.
- Do not install electronic or electrical equipment in the battery compartment.
- Do not smoke or use an open flame when working around batteries.

Temperature
Sensitivity

The capacity of lead-acid batteries is temperature sensitive. Battery capacity is rated at 77 °F (25 °C). At 0 °F (–20 °C), the Ah capacity is about half the rated capacity. You should consider temperature when designing your system.

- **Low Temperatures** If extremely low temperatures are expected where the inverter is going to be located, you should consider a heated equipment room. If the system is located in an unheated space, an insulated battery enclosure is recommended.
- **High Temperatures** The batteries should also be protected from high temperatures. These can be caused by high ambient temperatures, solar heating of the battery enclosure, or heat released by a nearby engine or generator. High battery temperatures shorten battery life and therefore you should ventilate the enclosure and use shade and insulation as appropriate.

Discharged
Batteries

Do not leave batteries in a discharged state for more than a day or two. They will undergo a chemical process (sulfation) that can permanently damage the battery. As well, batteries self-discharge over a period of three to six months, and they should be recharged periodically even if they are not being used.

Electrolyte
Level

If your batteries are not the “maintenance-free” type, check the electrolyte level at least once a month. Excessive fluid loss is a sign of overcharging. Replenish the electrolyte using only distilled water.

Battery Types

Battery Connections

Connections to battery posts must be made with permanent connectors that provide a reliable, low-resistance connection. Do not use alligator clips. Clean the connections regularly and prevent corrosion by using a protective spray coating or Vaseline.

Battery State of Charge

You can measure battery state of charge with a hydrometer or approximate state of charge with a voltmeter. Use a digital voltmeter that can display tenths or hundredths of a volt when measuring 10 to 30 volts. Make your measurements when the battery has not been charged or discharged for several hours. For a deep-cycle battery at 77° F (25° C), use the following table:

Battery Voltage	State of Charge
12.7–13.0 V	100%
12.5–12.6 V	80%
12.3–12.4 V	60%
12.1–12.2 V	40%
11.9–12.0 V	20%

C

Alternators and Charging Systems

Appendix C provides guidelines for recharging batteries from an alternator, from AC power, and from alternate energy sources.

A good charging system is important for the health of your batteries. Poor recharging methods can quickly damage batteries.

Charging System Requirements

Your charging system should be capable of delivering a charging current equal to 25% of the amp-hour capacity of your battery. For example, if you have a 200 Ah battery, the charging system should be able to deliver 50 amps. The charging system must also be able to charge each 12 volt battery up to approximately 14.4 volts and then drop back to a “float” voltage of 13.5–14 volts (or shut off).



CAUTION

Never operate the inverter directly from an alternator. To work properly, the inverter must be connected to a battery or a well-regulated, high-current DC power supply.

Charging With an Engine Alternator

Read the following information to determine whether your vehicle's standard alternator will be adequate by itself, whether you should install an alternator controller, or whether you need a high-output alternator.

Using a Standard Vehicle Alternator

A typical engine alternator (12 volts) may not be able to meet the requirements outlined above if your system uses large capacity batteries. Alternators are typically rated for the current they can deliver when they are cold. When in use, alternators heat up, and their output current capability drops by as much as 25 percent. Therefore, standard alternators with ratings of 40 to 105 amps only deliver a maximum of 30 to 80 amps in actual use and deliver even less as battery voltage rises. Many alternators cannot produce more than 13.6 volts when they are hot. As a result, a standard alternator may not be able to charge a large battery quickly and completely.

Two solutions are to install an alternator controller or to install a high-output alternator.

Using a Multi-stage Alternator Regulator

If your existing alternator charger is inadequate, you should consider installing a multi-stage alternator regulator. This will maximize the alternator's charging rate without exceeding proper battery charge voltages and ensure more rapid and complete charging.

Multi-stage alternator regulators, such as the Xantrex Alternator Regulator (XAR), are available from marine product dealers.

Using a High-Output Alternator

If the alternator charging is still inadequate after installing the XAR, heavy-duty alternators rated from 100 to 140 amps can replace standard alternators and produce the higher current required to charge multiple battery systems. They are available from RV and marine dealers, as well as auto parts suppliers.

Charging From AC Power

When recharging from AC power, use a good quality battery charger or RV converter that meets the requirements outlined in “Charging System Requirements” on page C-1.

For information about Xantrex’s battery chargers, visit our web site at www.xantrex.com.

Do not use chargers intended for occasional recharging of automotive starting batteries. These chargers are not intended for continuous use.

Charging From Alternative Energy Sources

You can also charge your batteries from alternative energy sources such as solar panels, wind, or hydro systems. Make sure you use the appropriate battery charge controller for your particular energy source.



CAUTION

Never operate the XM 1800 directly from an energy source such as a solar panel. Unregulated solar panels can output over 16 volts, which will damage the XM 1800 inverter. The inverter must be connected to a battery or a well-regulated, high-current DC power supply to work properly.

Warranty and Return Information

Warranty

What does this warranty cover? This Limited Warranty is provided by Xantrex Technology, Inc. (“Xantrex”) and covers defects in workmanship and materials in your Xantrex PRO Inverter (XM 1800 or XM 1000). This warranty period lasts for 1 year from the date of purchase at the point of sale to you, the original end user customer. You require proof of purchase to make warranty claims.

What will Xantrex do? Xantrex will, at its option, repair or replace the defective product free of charge, provided that you notify Xantrex of the product defect within the Warranty Period, and provided that Xantrex through inspection establishes the existence of such a defect and that it is covered by this Limited Warranty.

Xantrex will, at its option, use new and/or reconditioned parts in performing warranty repair and building replacement products. Xantrex reserves the right to use parts or products of original or improved design in the repair or replacement. If Xantrex repairs or replaces a product, its warranty continues for the remaining portion of the original Warranty Period or 90 days from the date of the return shipment to the customer, whichever is greater. All replaced products and all parts removed from repaired products become the property of Xantrex.

Xantrex covers both parts and labor necessary to repair the product, and return shipment to the customer via a Xantrex-selected non-expedited surface freight within the contiguous United States and Canada. Alaska and Hawaii are excluded. Contact Xantrex Customer Service for details on freight policy for return shipments outside of the contiguous United States and Canada.

How do you get service? If your product requires troubleshooting or warranty service, contact your dealer. If you are unable to contact your dealer, or the dealer is unable to provide service, contact Xantrex directly at:

Telephone: 1 800 670 0707 (toll-free in North America)

1 360 925 5097 (direct)

Fax: 1 360 925 5143 (direct)

Email: customerservice@xantrex.com

Direct returns may be performed according to the Xantrex Return Material Authorization Policy described in your product manual. For some products, Xantrex maintains a network of regional Authorized Service Centers. Call Xantrex or check our website to see if your product can be repaired at one of these facilities.

What proof of purchase is required? In any warranty claim, dated proof of purchase must accompany the product and the product must not have been disassembled or modified without prior written authorization by Xantrex.

Proof of purchase may be in any one of the following forms:

- The dated purchase receipt from the original purchase of the product at point of sale to the end user, or
- The dated dealer invoice or purchase receipt showing original equipment manufacturer (OEM) status, or
- The dated invoice or purchase receipt showing the product exchanged under warranty

Warranty and Return

What does this warranty not cover? This Limited Warranty does not cover normal wear and tear of the product or costs related to the removal, installation, or troubleshooting of the customer's electrical systems. This warranty does not apply to and Xantrex will not be responsible for any defect in or damage to:

- a) the product if it has been misused, neglected, improperly installed, physically damaged or altered, either internally or externally, or damaged from improper use or use in an unsuitable environment;
- b) the product if it has been subjected to fire, water, generalized corrosion, biological infestations, or input voltage that creates operating conditions beyond the maximum or minimum limits listed in the Xantrex product specifications including high input voltage from generators and lightning strikes;
- c) the product if repairs have been done to it other than by Xantrex or its authorized service centers (hereafter "ASCs");
- d) the product if it is used as a component part of a product expressly warranted by another manufacturer;
- e) the product if its original identification (trade-mark, serial number) markings have been defaced, altered, or removed.

Disclaimer

Product

THIS LIMITED WARRANTY IS THE SOLE AND EXCLUSIVE WARRANTY PROVIDED BY XANTREX IN CONNECTION WITH YOUR XANTREX PRODUCT AND IS, WHERE PERMITTED BY LAW, IN LIEU OF ALL OTHER WARRANTIES, CONDITIONS, GUARANTEES, REPRESENTATIONS, OBLIGATIONS AND LIABILITIES, EXPRESS OR IMPLIED, STATUTORY OR OTHERWISE IN CONNECTION WITH THE PRODUCT, HOWEVER ARISING (WHETHER BY CONTRACT, TORT, NEGLIGENCE, PRINCIPLES OF MANUFACTURER'S LIABILITY, OPERATION OF LAW, CONDUCT, STATEMENT OR OTHERWISE), INCLUDING WITHOUT RESTRICTION ANY IMPLIED WARRANTY OR CONDITION OF QUALITY, MERCHANTABILITY OR FITNESS FOR A PARTICULAR PURPOSE. ANY IMPLIED WARRANTY OF MERCHANTABILITY OR FITNESS FOR A PARTICULAR PURPOSE TO THE EXTENT REQUIRED UNDER APPLICABLE LAW TO APPLY TO THE PRODUCT SHALL BE LIMITED IN DURATION TO THE PERIOD STIPULATED UNDER THIS LIMITED WARRANTY.

IN NO EVENT WILL XANTREX BE LIABLE FOR ANY SPECIAL, DIRECT, INDIRECT, INCIDENTAL OR CONSEQUENTIAL DAMAGES, LOSSES, COSTS OR EXPENSES HOWEVER ARISING WHETHER IN CONTRACT OR TORT INCLUDING WITHOUT RESTRICTION ANY ECONOMIC LOSSES OF ANY KIND, ANY LOSS OR DAMAGE TO PROPERTY, ANY PERSONAL INJURY, ANY DAMAGE OR INJURY ARISING FROM OR AS A RESULT OF MISUSE OR ABUSE, OR THE INCORRECT INSTALLATION, INTEGRATION OR OPERATION OF THE PRODUCT.

Exclusions

If this product is a consumer product, federal law does not allow an exclusion of implied warranties. To the extent you are entitled to implied warranties under federal law, to the extent permitted by applicable law they are limited to the duration of this Limited Warranty. Some states and provinces do not allow limitations or exclusions on implied warranties or on the duration of an implied warranty or on the limitation or exclusion of incidental or consequential damages, so the above limitation(s) or exclusion(s) may not apply to you. This Limited Warranty gives you specific legal rights. You may have other rights which may vary from state to state or province to province.

Warning: Limitations On Use

Please note that the Xantrex PRO Inverter is not intended for use as an uninterruptible power supply and Xantrex makes no warranty or representation in connection with any use of the product for such purposes.

Return Material Authorization Policy

Before returning a product directly to Xantrex you must obtain a Return Material Authorization (RMA) number and the correct factory "Ship To" address. Products must also be shipped prepaid. Product shipments will be refused and returned at your expense if they are unauthorized, returned without an RMA number clearly marked on the outside of the shipping box, if they are shipped collect, or if they are shipped to the wrong location.

When you contact Xantrex to obtain service, please have your instruction manual ready for reference and be prepared to supply:

- The serial number of your product
- Information about the installation and use of the unit
- Information about the failure and/or reason for the return
- A copy of your dated proof of purchase

Record these details in "Information About Your System" on page WA-4.

Return Procedure

1. Package the unit safely, preferably using the original box and packing materials. Please ensure that your product is shipped fully insured in the original packaging or equivalent. This warranty will not apply where the product is damaged due to improper packaging.
2. Include the following:
 - The RMA number supplied by Xantrex Technology, Inc. clearly marked on the outside of the box.
 - A return address where the unit can be shipped. Post office boxes are not acceptable.
 - A contact telephone number where you can be reached during work hours.
 - A brief description of the problem.
3. Ship the unit prepaid to the address provided by your Xantrex customer service representative.

If you are returning a product from outside of the USA or Canada In addition to the above, you **MUST** include return freight funds and are fully responsible for all documents, duties, tariffs, and deposits.

If you are returning a product to a Xantrex Authorized Service Center (ASC) A Xantrex return material authorization (RMA) number is not required. However, you must contact the ASC prior to returning the product or presenting the unit to verify any return procedures that may apply to that particular facility.

Out of Warranty Service

If the warranty period for your Xantrex PRO Inverter has expired, if the unit was damaged by misuse or incorrect installation, if other conditions of the warranty have not been met, or if no dated proof of purchase is available, your inverter may be serviced or replaced for a flat fee.

To return your Xantrex PRO Inverter for out of warranty service, contact Xantrex Customer Service for a Return Material Authorization (RMA) number and follow the other steps outlined in “Return Procedure” on page WA-3.

Payment options such as credit card or money order will be explained by the Customer Service Representative. In cases where the minimum flat fee does not apply, as with incomplete units or units with excessive damage, an additional fee will be charged. If applicable, you will be contacted by Customer Service once your unit has been received.

Information About Your System

As soon as you open your Xantrex PRO Inverter package, record the following information and be sure to keep your proof of purchase.

- Product Numbers 806-1010 (XM 1000), 806-1810 (XM 1800)
- Serial Number (on DC end) _____
- Purchased From _____
- Purchase Date _____

If you need to contact Customer Service, please record the following details before calling. This information will help our representatives give you better service.

- Type of installation (e.g. RV, truck) _____
 - Length of time inverter has been installed _____
 - Battery/battery bank size _____
 - Battery type (e.g. flooded, sealed gel cell, AGM) _____
 - DC wiring size and length _____
 - Alarm sounding? _____
 - Description of indicators on front panel _____
 - Appliances operating when problem occurred _____
 - Description of problem _____
-